

Lion75

Artikelnummer	ZB.Li75
Spannung	12,8 V
Kapazität	75 AH / 960 Wh
Kaltstart	750 A/EN
Effizienz	99 %
Selbstentladung	< 1 % per Monat

Max. Entladestrom	140 A
Dauer Entladestrom	105 A
Norm. Entladestrom	70 A
Entladeschlussspannung	10 V

Max. Ladestrom	70 A
Schnellladestrom	35 A
Empfohlener Ladespannung	14.2 V - 14.6 V
Ladecharakteristik	CC / CV

Temperaturbereich (Entladung)	-25°C ~ 60°C
Temperaturbereich (Ladung)	0°C ~ 45°C
Temperaturbereich (Lagerung)	-30°C ~ 60°C

Zellentyp	LiFePO ₄ Prismatic
Technologie	LFP / LiFePO ₄

Batterie Management System	BMS integriert
Überwachung	Bluetooth 4.0 und Smartphone-App

Box	L3
Boxmaterial	PVC + Schrumpffolie
Schutzart	IP65

Gewicht	10.0 kg
Garantie	2 (1*) Jahre Herstellergarantie
Versandklassifizierung	UN 3480, CLASS 9
B x H x T in mm	275 x 175 x 190

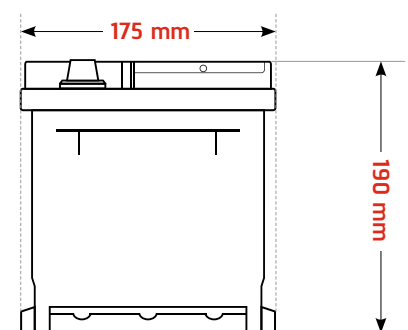
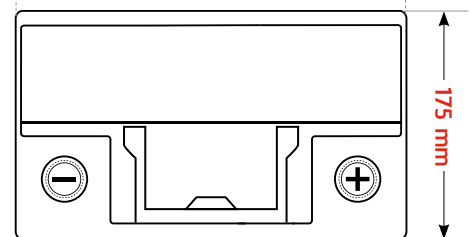
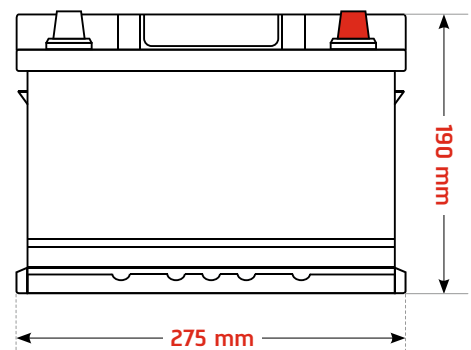

Schaltung **0**

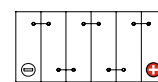

Polanschluss **1**

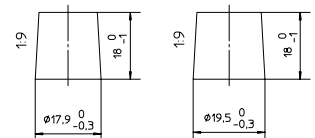

Bodenleiste **B13**

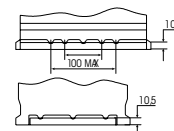

Zykluslebensdauer in Bezug auf die Entladungstiefe

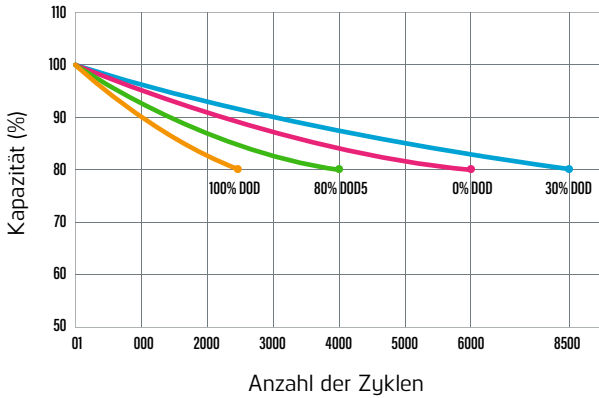

Entladeleistung

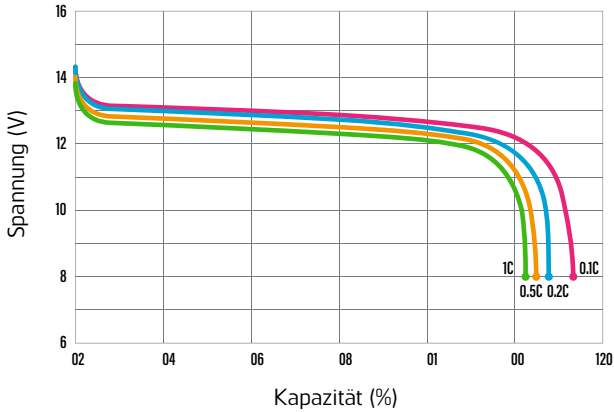

Temperaturauswirkungen bei Kapazitäten

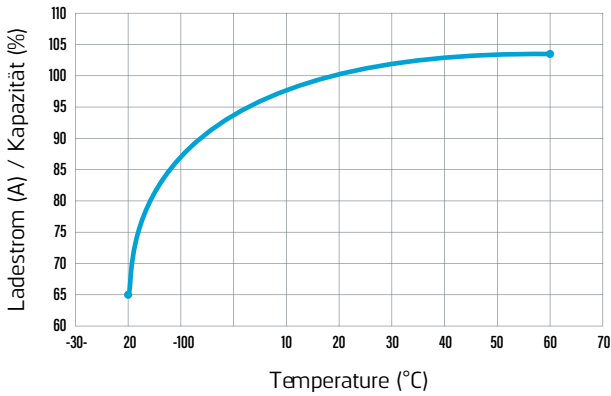

Ladecharakteristik für konstante Spannung

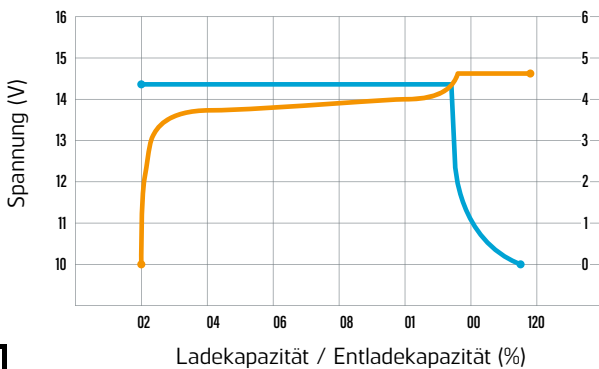

Vorteile :

- ✓ neueste und absolut sichere Lithium-Technologie (LiFePo4)
- ✓ Gewichtsersparnis bis zu 70%
- ✓ extrem lange Lebensdauer mit extrem hoher Zyklenfestigkeit
- ✓ schnelle und effiziente Ladung und Entladung
- ✓ geringe Selbstentladung
- ✓ integriertes BMS (Batterie Management System)
- ✓ eingebauter Sicherheitsschutz
- ✓ umweltfreundlich
- ✓ absolut wartungsfrei
- ✓ 2 (1*) Jahre Herstellergarantie
- ✓ 10 Jahre Lebensdauer
- ✓ mobiles Überwachen über Bluetooth-App



Lion App :

Für die Verbindung zwischen Batterie und Mobilgerät muss ihr Gerät die Bluetooth Version 4.0 unterstützen.



Anwendung :

- ✓ PKW, Wohnmobile, Caravan, Marine
- ✓ E-Werkzeuge, Bodenkehrmaschine
- ✓ Kommunikationssysteme, Solar, Windkraftanlagen
- ✓ Notbeleuchtung, EPS- und USV-Systeme

