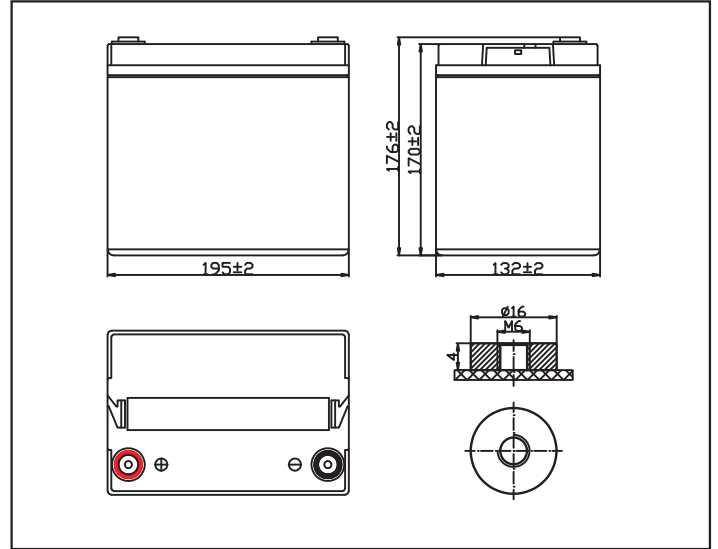

MODEL: OT35-12
NO.: 302010005-00254

Plane Chart:

Unit:(mm) Terminal type:(T1)

Parameter Chart:

Volts		12V	
Capacity(25°C)	20 hours rate (1.75A)	35Ah	
Discharge Current Testing (25°C)	20 I ₂₀ rate (35A,27min)	31min	
	60 I ₂₀ rate (105A,7min)	7min	
Internal Resistance	Full Charged Battery 25°C	9mΩ	
Capacity Affected By Temperature	40°C	104%	
	25°C	100%	
	0°C	83%	
	-15°C	65%	
Residual Capacity (25°C)	Capacity After 3 Months Storage	91%	
	Capacity After 6 Months Storage	82%	
	Capacity After 12 Months Storage	65%	
Charge (Constant Voltage)	Cycle (25°C)	Initial Charging Current Less Than 10.5A Voltage 14.5~14.9V	
	Float (25°C)	Charge Voltage 13.6~13.8V	
Weight (Approx)		10.3Kg	

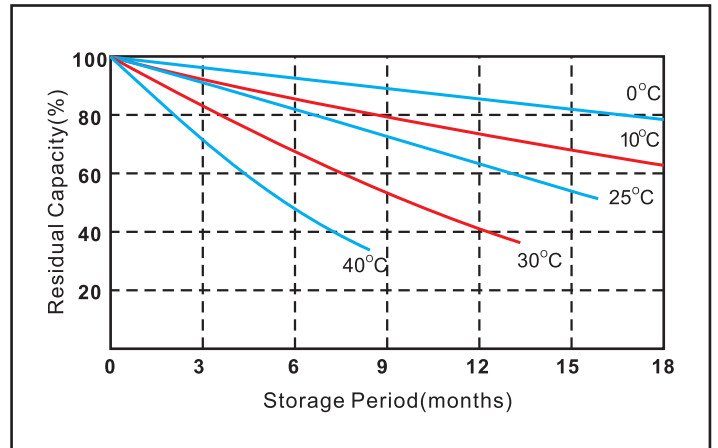
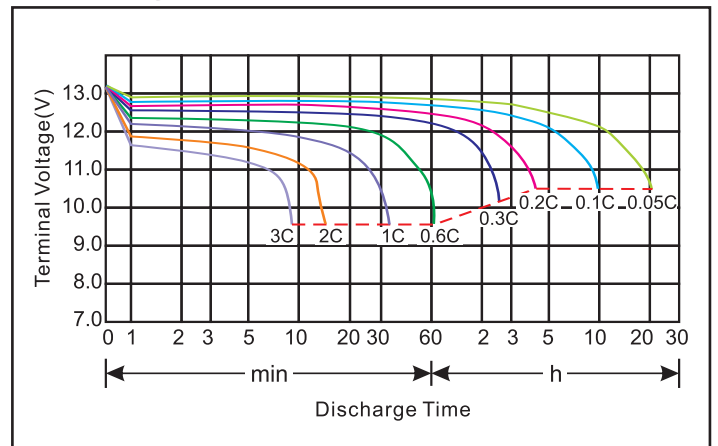
Residual Capacity

Discharge Current 25°C

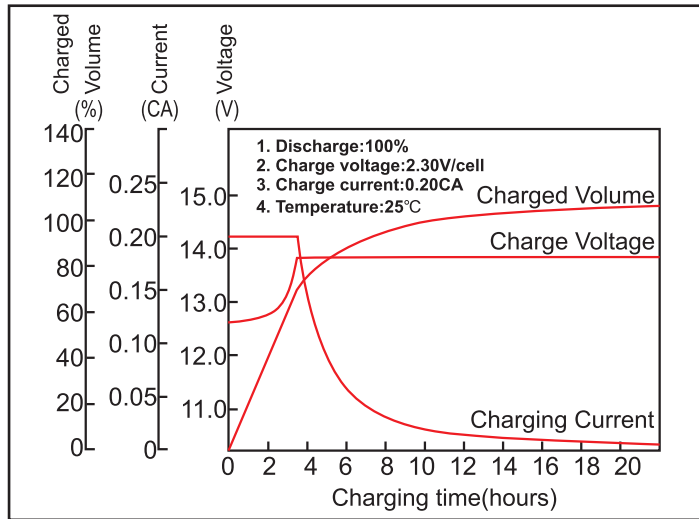
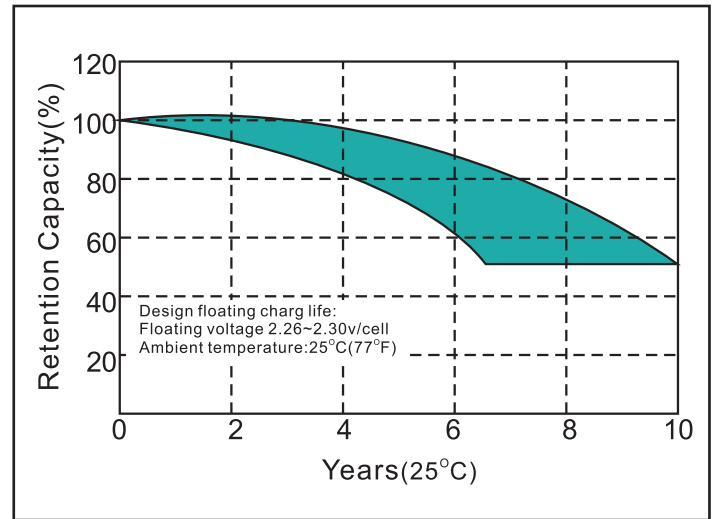
★The above are average and data obtained from the first 3 charge/discharge cycles. These are not minimum values.

MODEL: OT35-12
NO.: 302010005-00254
Constant voltage charging characteristics

Float Life

Constant Current Discharge Characteristics (A, 25°C)

F.V/Time	5min	10min	15min	30min	60min	2h	3h	5h	8h	10h	20h
9.60V	107.6	69.8	58.6	35.0	20.7	11.9	8.72	5.82	3.70	3.40	1.80
10.2V	103.5	67.2	56.2	33.6	20.0	11.8	8.53	5.70	3.62	3.35	1.78
10.5V	100.2	65.0	54.8	33.0	19.5	11.7	8.38	5.56	3.56	3.30	1.75
10.8V	96.4	63.1	53.5	32.1	19.0	11.6	8.22	5.53	3.50	3.20	1.65

Constant Power Discharge Characteristics (Watt, 25°C)

F.V/Time	5min	10min	15min	30min	60min	2h	3h	5h	8h	10h	20h
9.60V	1131.5	752.5	640.6	392.2	235.9	137.4	102.5	68.7	43.7	40.2	20.9
10.2V	1101.1	725.4	614.5	376.2	228.0	136.2	100.2	67.4	42.8	39.6	20.6
10.5V	1077.1	702.0	602.1	370.0	216.5	135.2	98.8	66.4	42.0	39.1	20.1
10.8V	1057.2	690.5	592.2	360.3	205.0	134.2	96.6	65.4	41.6	37.9	19.3

Capacity Factors With Different Temperature

Battery Type		-20°C	-10°C	0°C	5°C	10°C	20°C	25°C	30°C	40°C	45°C
Battery	12V	50%	70%	83%	85%	90%	98%	100%	102%	104%	105%

★The above are average and data obtained from the first 3 charge/discharge cycles. These are not minimum values.