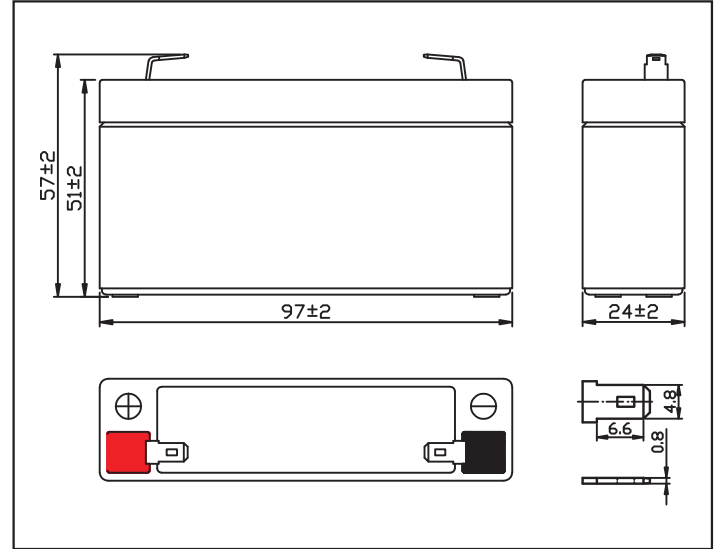

**MODEL: OT1.3-6**
**NO.: 302010005-00178**

**Plane Chart:**

Unit:(mm) Terminal type:(F1)

**Parameter Chart:**

Volts		6V	
Capacity(25°C)	20 hours rate (0.065A)	1.3Ah	
Discharge Current Testing (25°C)	20 I <sub>20</sub> rate (1.3A,27min)	32min	
	60 I <sub>20</sub> rate (3.9A,7min)	7min	
Internal Resistance	Full Charged Battery 25°C	82mΩ	
Capacity Affected By Temperature	40°C	104%	
	25°C	100%	
	0°C	83%	
	-15°C	65%	
Residual Capacity (25°C)	Capacity After 3 Months Storage	91%	
	Capacity After 6 Months Storage	82%	
	Capacity After 12 Months Storage	65%	
Charge (Constant Voltage)	Cycle (25°C)	Initial Charging Current Less Than 0.39A Voltage 7.25~7.45V	
	Float (25°C)	Charge Voltage 6.8~6.9V	
Weight (Approx)		0.29Kg	

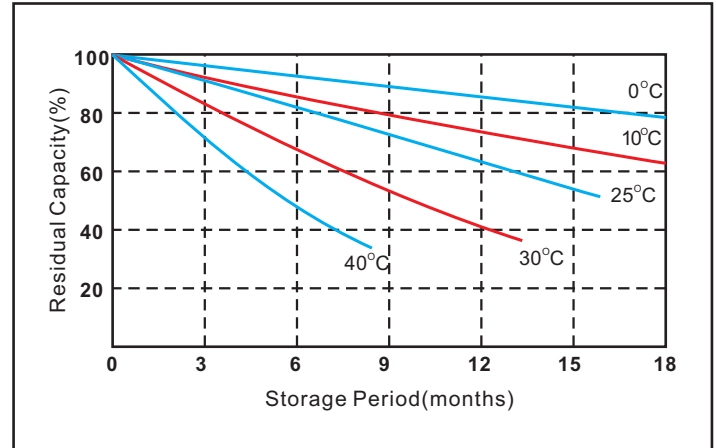
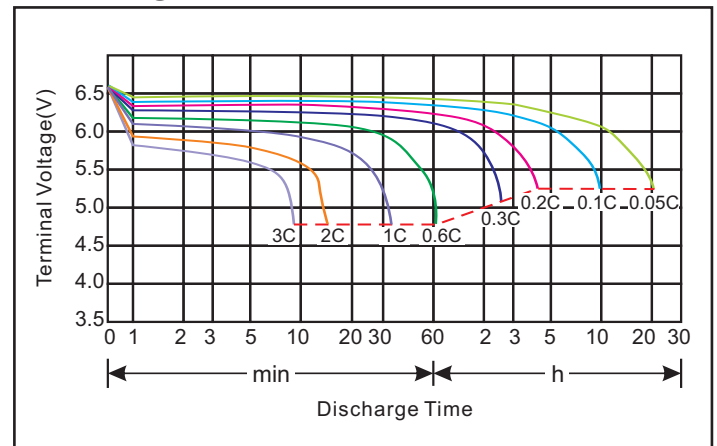
**Residual Capacity**

**Discharge Current 25°C**

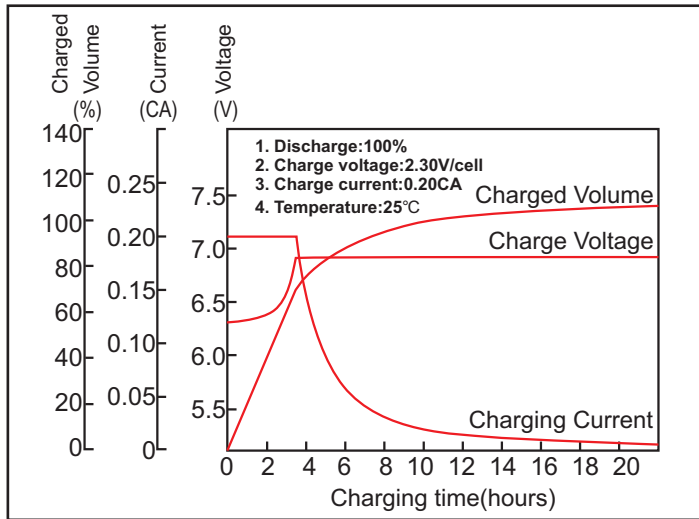
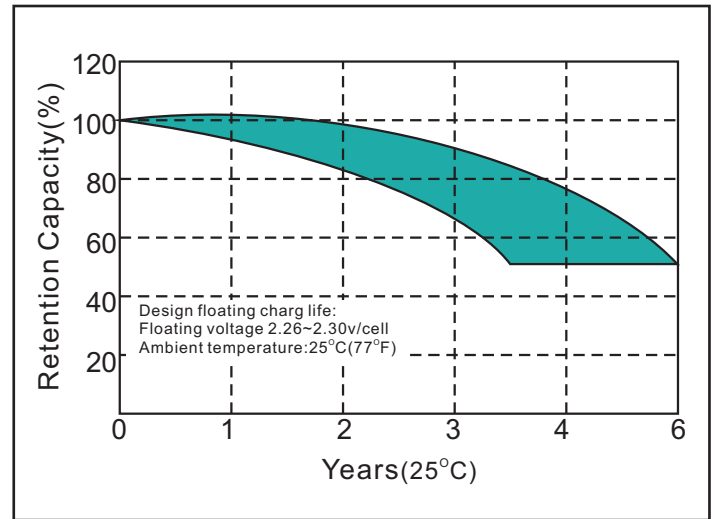
★The above are average and data obtained from the first 3 charge/discharge cycles. These are not minimum values.

**MODEL: OT1.3-6**
**NO.: 302010005-00178**
**Constant voltage charging characteristics**

**Float Life**

**Constant Current Discharge Characteristics (A, 25°C)**

F.V/Time	5min	10min	15min	30min	60min	2h	3h	5h	8h	10h	20h
4.80V	4.53	2.81	2.11	1.25	0.78	0.43	0.32	0.21	0.14	0.12	0.066
5.10V	4.31	2.62	1.98	1.19	0.75	0.42	0.31	0.21	0.14	0.11	0.065
5.25V	4.18	2.56	1.92	1.16	0.73	0.42	0.30	0.20	0.13	0.11	0.066
5.40V	4.02	2.43	1.85	1.13	0.72	0.41	0.29	0.19	0.13	0.10	0.064

**Constant Current Discharge Characteristics (Watt, 25°C)**

F.V/Time	5min	10min	15min	30min	60min	2h	3h	5h	8h	10h	20h
4.80V	24.48	15.31	11.61	7.00	4.45	2.47	1.86	1.23	0.83	0.71	0.39
5.10V	23.72	14.54	11.09	6.72	4.29	2.47	1.80	1.17	0.83	0.65	0.39
5.25V	23.18	14.34	10.85	6.61	4.22	2.46	1.76	1.12	0.77	0.65	0.39
5.40V	22.51	13.73	10.55	6.50	4.11	2.40	1.70	1.12	0.77	0.60	0.38

**Capacity Factors With Different Temperature**

Battery Type		-20°C	-10°C	0°C	5°C	10°C	20°C	25°C	30°C	40°C	45°C
Battery	6V	50%	70%	83%	85%	90%	98%	100%	102%	104%	105%

★The above are average and data obtained from the first 3 charge/discharge cycles. These are not minimum values.