

NEATA

GEL battery series

Datasheet : NTG12-55(12V55AH)

Nominal Voltage	12V
Number of cell	6
Design Life	20years
Nominal Capacity 77°F(25°C)	
20 hour rate (2.75A, 10.5V)	55.0Ah
10 hour rate (5.17A, 10.5V)	51.7Ah
5 hour rate (9.05A, 10.5V)	45.25Ah
1 hour rate (34.0A, 9.6V)	34.0Ah
Internal Resistance	
Fully Charged battery 77°F(25°C)	≤5.8mOhms
Self-Discharge	
3% of capacity declined per month at 20°C(average)	
Operating Temperature Range	
Discharge	-20~60°C
Charge	-10~60°C
Storage	-20~60°C
Max. Discharge Current 77°F(25°C)	550(5s)
Short Circuit Current	1400A
Charge Methods: Constant Voltage Charge 77°F(25°C)	
Cycle use	2.40-2.45VPC
Maximum charging current	16.5A
Temperature compensation	-30mV/°C
Standby use	13.6-13.8V
Temperature compensation	-20mV/°C



Wide Range Temperature



Warranty



Maintenance Free



GEL Technology



easy use



long life

Mechanical Characteristics

Length(mm / inch)	229 / 9.08
Width(mm / inch)	138 / 5.47
Height(mm / inch)	208 / 8.25
Total Height(mm / inch)	213 / 8.45
Approx. Weight(Kg / lbs)	16.0 / 35.2

* Weight deviation: ± 5%

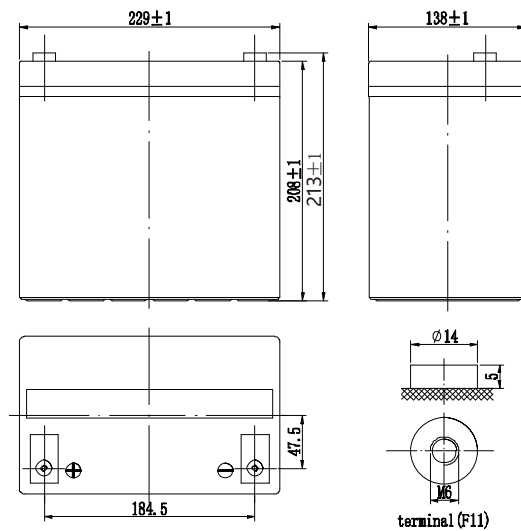

Technical Characteristics

Discharge Constant Current (Amperes at 77°F25°C)

End Point	Volts/Cell	10min	15min	30min	45min	1h	3h	5h	10h
1.60V	124	96.5	57.8	42.3	34.6	14.5	9.77	5.35	
1.65V	119	92.6	56.0	41.1	33.7	14.1	9.52	5.32	
1.70V	111	88.0	54.2	39.9	32.8	13.8	9.35	5.28	
1.75V	102	83.3	52.5	38.8	32.0	13.5	9.18	5.24	
1.80V	96.0	77.2	50.6	37.6	31.2	13.2	9.01	5.17	

Discharge Constant Power (Watts at 77°F25°C)

End Point	Volts/Cell	10min	15min	30min	45min	1h	2h	3h	5h
1.60V	220	177	108	83.6	67.9	38.6	28.8	18.7	
1.65V	216	172	106	82.4	66.3	37.7	28.2	18.5	
1.70V	205	164	104	80.7	64.8	36.9	27.6	18.1	
1.75V	192	157	102	78.9	63.3	36.1	27.0	17.9	
1.80V	179	150	101	76.9	63.1	35.5	26.4	17.8	

(Note)The above characteristics data are average values obtained within three charge/discharge cycles. All data shall be changed without notice, Neata reserves the right to explain and update the information.

SHENZHEN OFFICE (CHINA)
 Tel: +86-755-2691-9474
 Fax: +86-755-2691-9474

Recognized under CE/IEC and certified by ISO9001,14001



NEATA GEL battery series

Datasheet : NTG12-55(12V55AH)

Discharge Characteristics Curve

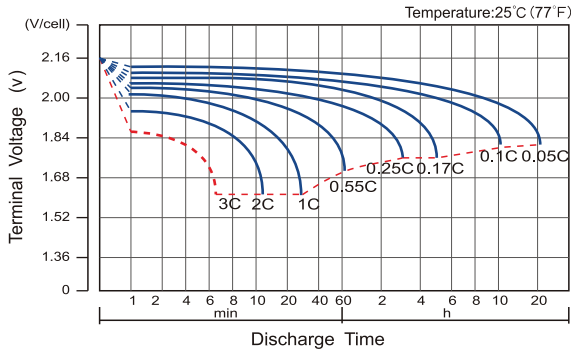

Charge Characteristic Curve For Standby Use

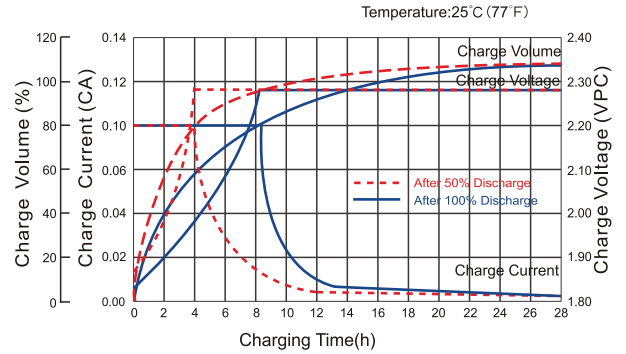

Cycle Life In Relation To Depth Of Discharge

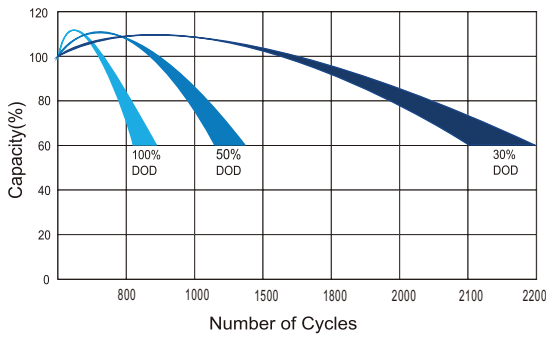

Temperature Effects On Capacity

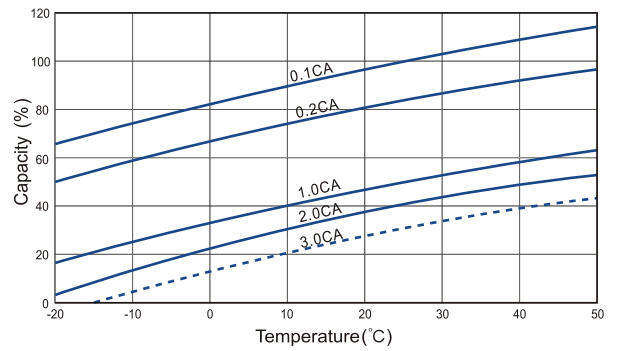

Relationship Between Charging Voltage And Temperature

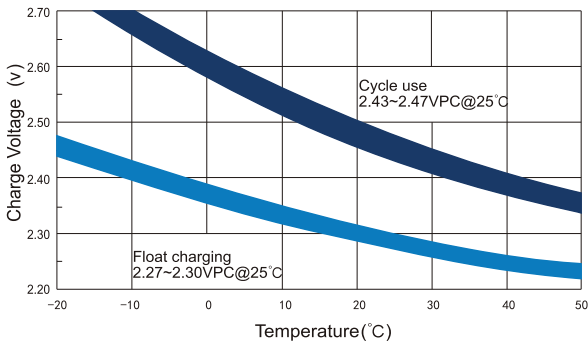

Storage Characteristics

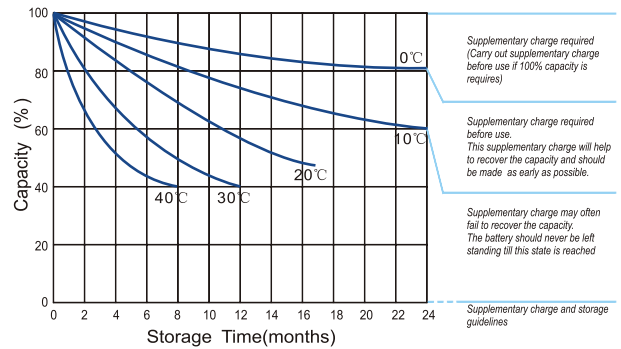

Effect Of Temperature On Long Term Life

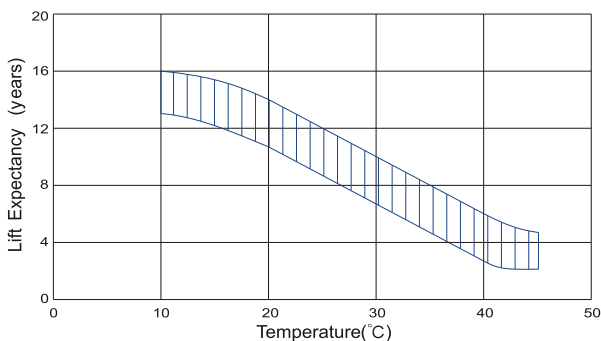

Life Characteristics Of Standby Use

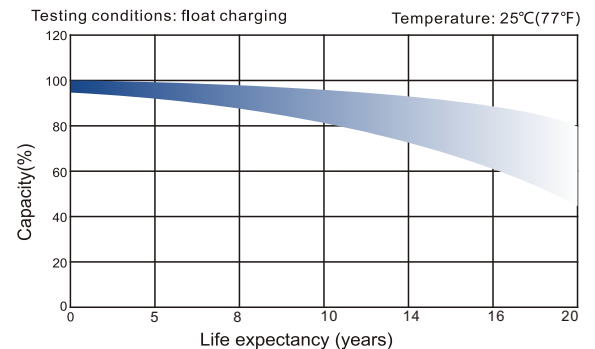

SHENZHEN OFFICE (CHINA)
 Tel: +86-755-2691-9474
 Fax: +86-755-2691-9474

Recognized under CE/IEC and certified by ISO9001,14001

