

NEATA

GEL battery series

Datasheet : NTG12-45(12V45AH)

Nominal Voltage	12V
Number of cell	6
Design Life	20 years
Nominal Capacity 77°F(25°C)	
20 hour rate (2.25A, 10.5V)	45.0Ah
10 hour rate (4.18A, 10.5V)	41.8Ah
5 hour rate (7.34A, 10.5V)	36.7Ah
1 hour rate (24.9A, 9.6V)	27.6Ah
Internal Resistance	
Fully Charged battery 77°F(25°C)	≤8.0mOhms
Self-Discharge	
3% of capacity declined per month at 20°C(average)	
Operating Temperature Range	
Discharge	-20~60°C
Charge	-10~60°C
Storage	-20~60°C
Max. Discharge Current 77°F(25°C)	450(5s)
Short Circuit Current	1050A
Charge Methods: Constant Voltage Charge 77°F(25°C)	
Cycle use	2.40-2.45VPC
Maximum charging current	13.5A
Temperature compensation	-30mV/°C
Standby use	13.6-13.8V
Temperature compensation	-20mV/°C



Wide Range Temperature



Warranty



Maintenance Free



GEL Technology



easy use



long life

Mechanical Characteristics

Length(mm / inch)	197.5 / 7.72
Width(mm / inch)	165.5/ 6.54
Height(mm / inch)	170 / 7.17
Total Height(mm / inch)	170 / 7.17
Approx. Weight(Kg / lbs)	13.3/ 29.26

* Weight deviation: ± 5%

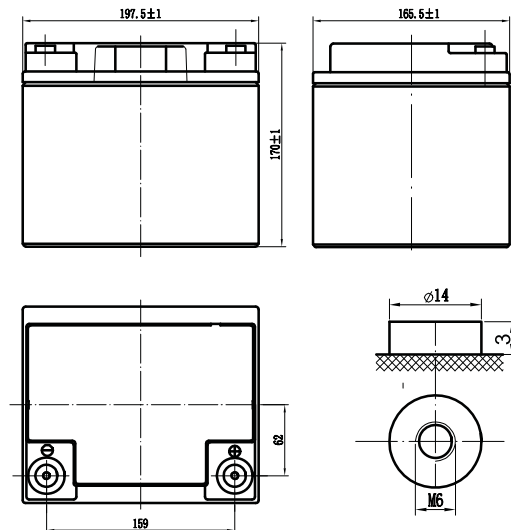

Technical Characteristics

Discharge Constant Current (Amperes at 77°F25°C)

End Point	10min	15min	30min	1h	3h	5h	10h	20h
1.60V	96.0	75.5	44.6	27.6	11.7	7.76	4.26	2.37
1.65V	91.2	72.1	44.4	27.2	11.5	7.62	4.24	2.33
1.70V	86.4	70.8	42.8	26.8	11.2	7.48	4.22	2.30
1.75V	81.6	66.9	38.9	26.5	11.0	7.34	4.20	2.27
1.80V	76.8	64.0	38.0	26.1	10.8	7.26	4.18	2.25

Discharge Constant Power (Watts at 77°F25°C)

End Point	10min	15min	30min	45min	1h	2h	3h	5h
1.60V	180	143	96.1	73.1	58.3	32.8	24.3	15.7
1.65V	167	136	84.7	66.3	54.0	30.4	22.6	14.7
1.70V	159	131	81.7	64.0	53.2	30.0	22.3	14.6
1.75V	150	123	79.8	62.8	52.3	29.6	22.1	14.4
1.80V	147	122	78.0	61.7	51.5	29.2	21.8	14.1

(Note)The above characteristics data are average values obtained within three charge/discharge cycles. All data shall be changed without notice, Neata reserves the right to explain and update the information.

SHENZHEN OFFICE (CHINA)
 Tel: +86-755-2691-9474
 Fax: +86-755-2691-9474

Recognized under CE/IEC and certified by ISO9001,14001



NEATA GEL battery series

Datasheet : NTG12-45(12V45AH)

Discharge Characteristics Curve

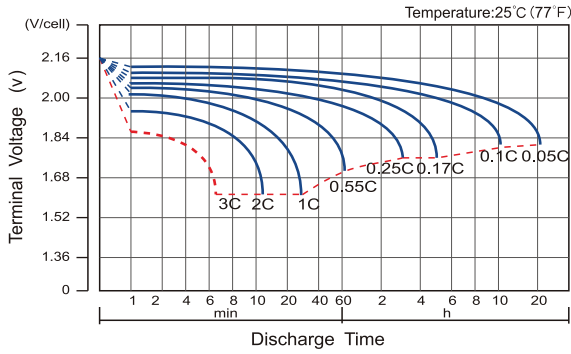

Charge Characteristic Curve For Standby Use

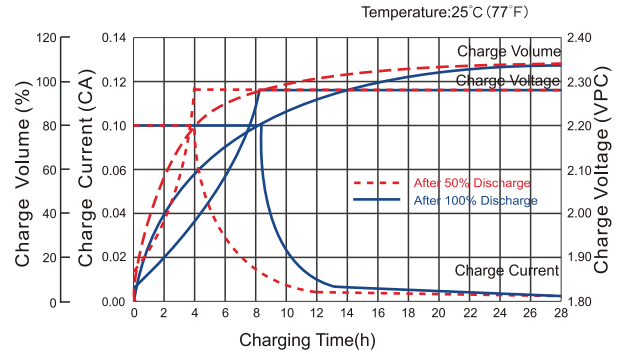

Cycle Life In Relation To Depth Of Discharge

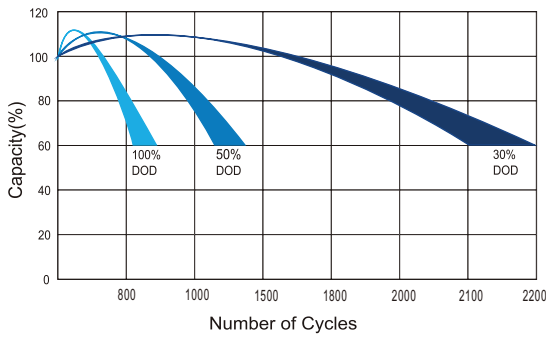

Temperature Effects On Capacity

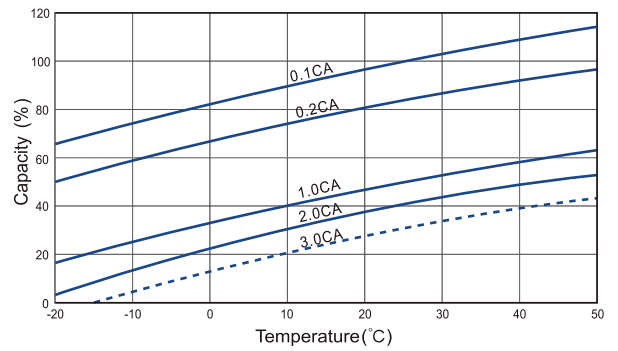

Relationship Between Charging Voltage And Temperature

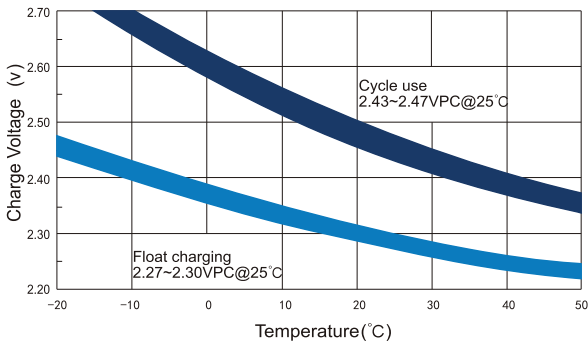

Storage Characteristics

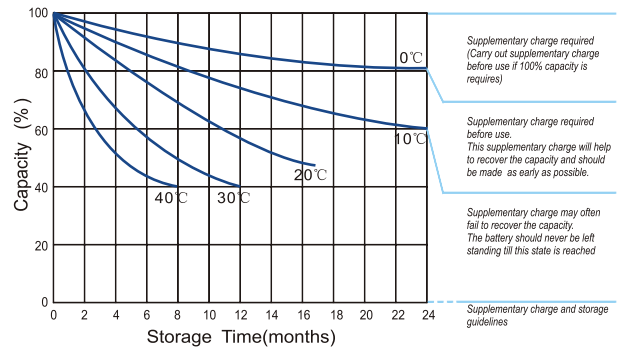

Effect Of Temperature On Long Term Life

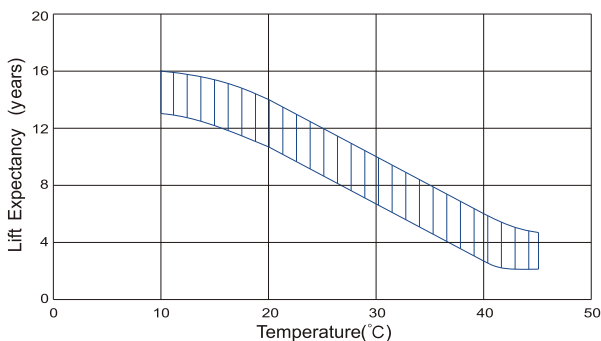

Life Characteristics Of Standby Use

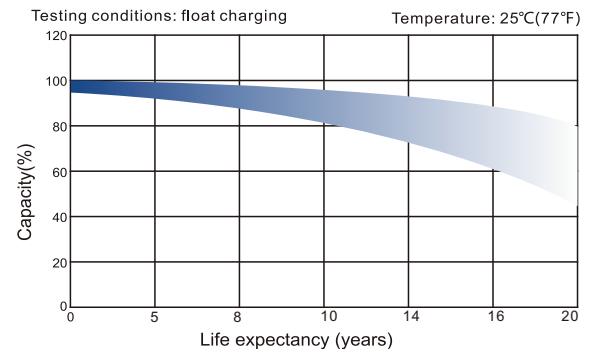

SHENZHEN OFFICE (CHINA)
 Tel: +86-755-2691-9474
 Fax: +86-755-2691-9474

Recognized under CE/IEC and certified by ISO9001,14001

