



HC15 SPECIFICATIONS

BATTERY DESIGN

- Absorbent glass mat (AGM) technology
- 12V battery VRLA
- Can be mounted in any orientation except inverted.
- US DOT and IATA certified non-spillable
- Sealed Construction (Non-Spillable Battery)
- Can be fitted with TP brass automotive adaptor on request
- Shipped fully charged - just install and go!
- Suited for repeated discharges such as running your vehicle with winches or other electrical accessories.

PERFORMANCE FEATURES

- ✧ PHCA: 370A at 80°F (27°C) for 5 seconds
- ✧ PCCA: 210A at 0°F (-18°C) for 5 seconds
- ✧ CCA: 156A at 0°F (-18°C)
- ✧ CA/MCA: 190A at 32°F (0°C)
- ✧ HCA: 220A at 80°F (27°C)
- ✧ Reserve capacity: 25 minutes
- ✧ Short circuit current: 880A
- ✧ Operation temperature range: -5°F (-15°C) to 122°F (50°C)

Nominal Dimensions

Length		Width		Height		Total Height		Weight	
mm	in	mm	in	mm	in	mm	in	kg	pound
200	7.87	78	3.07	134	5.25	138	5.43	5.55	12.24

HIGH RATE DISCHARGE AT 77°F (25°C)

5 sec.	10 sec.	20 sec.	30 sec.
370A	335A	287A	255A

EXTENDED DISCHARGE AT 77°F (25°C) TO 10.02V

5min	15min	1hr	3hr	5hr	10hr	20hr
70.7A	32.4A	10.9A	4.29A	2.73A	1.45A	0.76A

PHYSICAL CHARACTERISTICS

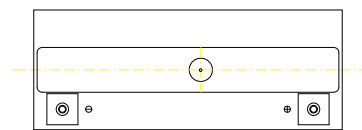
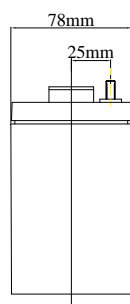
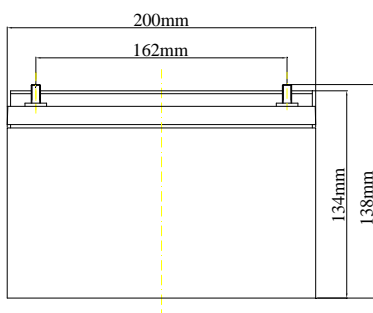

Terminal: M6M
unit:mm

